

INSTRUCTIONS FOR USE

SNOREMD[®]+

Class 1 Medical Device

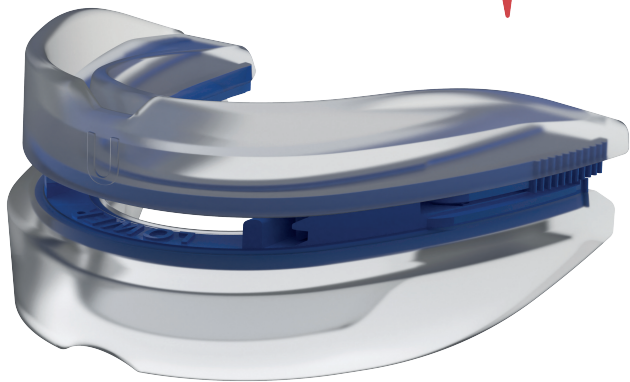





READ CAREFULLY

SnoreMD Fitting Video

Scan the below QR Code with your smart phone and watch our “Fitting video”.



UTENSILS REQUIRED

Timer	
A medium sized pot	
Bowl of tap water	
A spatula, or tongs	

NB: DO NOT USE MICROWAVE OR KETTLE

**BEFORE STARTING
THE MOULDING PROCESS,
FAMILIARISE YOURSELF WITH
THE DEVICES' "UPPER TRAY",
THIS IS MARKED ON THE FRONT
OF YOUR SnoreMD
BY THE LETTER "U".**

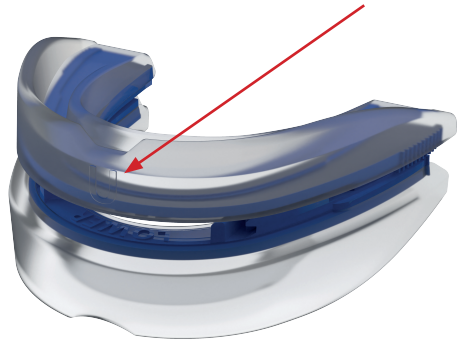

HOW TO MOULD YOUR SnoreMD

- Step 1** Leave SnoreMD on the factory setting of 3. Please do not pull apart prior to moulding.
- Step 2** Fill a medium sized pot with water $\frac{3}{4}$ to the top and bring to the boil on the stove.
- Step 3** After the water has come to the boil, turn the heat off and ensure the pot has then been carefully removed from the heated stove top element.

Step 4 Have your timer ready and only once the water has physically stopped bubbling, place your SnoreMD on the surface of the boiled water for a strict 30 seconds (do not submerge the device, you want SnoreMD floating at the top so it doesn't sink or touch the sides of the pot).

Step 5 Without applying too much pressure with the tongs, carefully remove SnoreMD by picking up the device from the back adjustment section (this is the part that fits to the back of your mouth).

Step 6 Dip SnoreMD into a bowl of room temp water for 3 seconds to rinse residual hot water off, slowly position in your mouth and then bite down for 30 seconds. Suck in to form a vacuum and use your fingers to push the side of your gums so the warmed material moulds to your teeth and jaw.

Step 7 Remove your SnoreMD from your mouth and place into a bowl of cold water, this will set the mould.

Step 8 You are now ready to begin using your SnoreMD. Start using at the factory setting 3. After using for two nights and becoming used to wearing your SnoreMD, (if necessary) gradually adjust in 1mm increments until your snoring starts to subside.

HELPFUL TIPS

1. We suggest you begin using your SnoreMD while watching TV/ reading a book **for a couple of hours per night**, before introducing it into your night time routine. This is to allow your body to get used to wearing the device.
2. After 2-3 nights, start wearing your SnoreMD to bed. It is completely normal for it to take **1-3 weeks to get used to wearing your SnoreMD for the entire night**. Be patient.
3. If you wake up in the middle of the night and are bothered by your SnoreMD, just take it out and go back to sleep.
Each night you should be able to sleep longer with your SnoreMD.
4. It is normal for some people to experience excess salivation, dry mouth and tenderness of the jaw, teeth and gums during initial use of your SnoreMD. This will subside over time.
5. Your SnoreMD works best if you sleep on your side or stomach.

ADJUSTMENT INSTRUCTIONS

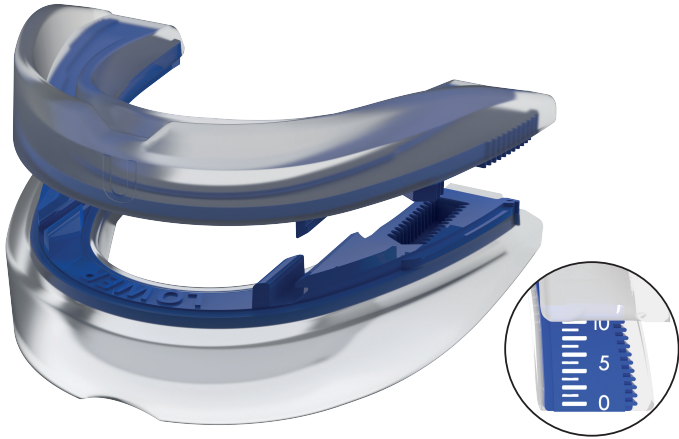

If you are required to adjust your SnoreMD from the factory setting of '3' please use the following steps.

1. To adjust your SnoreMD forward, pull the lower and upper trays completely apart so you now have two separate pieces.
2. To reposition your SnoreMD find the desired increment on the adjustable increment scale on the upper tray and align the lower piece of your SnoreMD on the preferred adjustment (1–10).
3. Make sure both sides are adjusted to the same setting, if not, your SnoreMD will be less effective.
4. 'Click' the upper and lower trays back into place - this may require some force to ensure they are securely in place.

CARE & HANDLING

5. The lower tray should now sit slightly forward - this will help open the airway to maximise airflow and your snoring will diminish.
6. Gradually adjust your SnoreMD by 1mm increments until improvement is noticed. If jaw pain is noticed, go back to the last comfortable setting for a further few nights.

- Prior to using your SnoreMD, brush your teeth.
- Store your SnoreMD in its case in a cool dry place.
- Periodically, clean your SnoreMD with a toothbrush and toothpaste.
- Do not use harsh chemicals or household cleaning products like bleach, ammonia or mouthwash.
- Manufacturer recommends replacing every 12 months. **NB:** Product life is dependent on the patients use and post use care. Longevity and integrity of this device may vary from patient to patient.

CONTRAINDICATIONS

SnoreMD should not be used if you:

- Are under the age of 18.
- Have a history of TMD, temporomandibular disorder.
- Have worn dental implants or had Orthodontic work within the past year.
- Have dentures or are undergoing orthodontic treatment. **NB:** May be suitable for partial dentures.
- Have loose teeth, abscesses or severe gum disease.
- Have central sleep apnea.
- Have COPD or other respiratory diseases.

WARNINGS

Use of SnoreMD may cause:

- Tooth movement or changes in dental occlusion.
- Gingival or dental soreness.
- Pain or soreness to the temporomandibular joint.

CAUTION: If you experience prolonged discomfort, bleeding, loose or moving teeth, excess jaw pain, limited jaw movement, bite changes or other problems that may be associated with using SnoreMD, immediately discontinue use and contact your dentist or physician for advice.



Made in Australia

SPONSOR

APAC Health & Medical Distributors PTY LTD
Regatta 1 Business Centre, 2 Innovation Pkwy,
Birtinya QLD 4575 Australia

www.snoremd.com.au



**APAC
Health & Medical**

Sales · Marketing · Distribution